

YSF系列Φ50mm以下口径的压力释放阀

YSF series pressure relief valves with diameters below 50mm

一、简介、型号说明及使用范围 Introduction, Model Description, and Scope of Use

YSF 系列Φ50mm 以下口径的压力释放阀是一种新型压力释放阀。本产品用于保护油浸电气设备的油箱，例如变压器、高压开关、电力电容器、电抗器、有载分接开关等。

The YSF series pressure relief valve with a diameter of less than 50mm is a new type of pressure relief valve. This product is used to protect oil tanks of oil immersed electrical equipment, such as transformers, high-voltage switches, power capacitors, reactors, on load tap changers, etc.

1.1 型号说明 Model Description

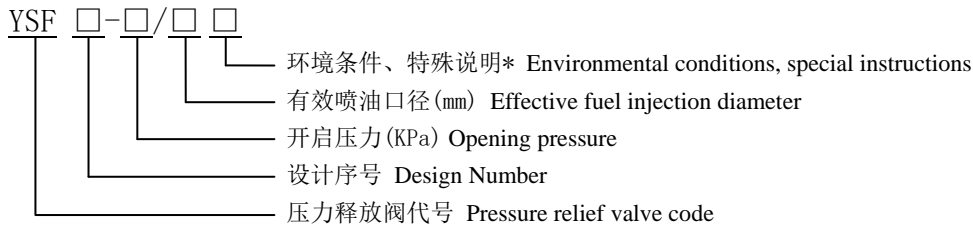

标注实例: YSF9—35/50DSKJTHB 表示第 9 次设计的喷油口径为Φ50mm, 开启压力 35KPa, (D) 带定向导油功能, (K) 带电气报警信号 (SK) 双电气报警信号, (J) 带机械报警信号, (TH) 湿热带地区用, (B) 带闭锁装置的压力释放阀。

Example annotation: YSF9—35/50DSKJTHB represents the 9th design with a fuel injection diameter of 50mm, an opening pressure of 35KPa, (D) with directional oil guide function, (K) with electrical alarm signal (SK) dual electrical alarm signal, (J) with mechanical alarm signal, (TH) for use in humid and hot regions, and (B) pressure release valve with locking device.

使用范围: (a). 安装位置: 油箱盖上、升高座上或油箱上部侧壁上; (b). 环境温度: -30℃~+70℃ (可根据用户需求定制最高可支持 -45℃~+70℃), 工作环境要求: -30℃~+115℃ (可根据用户需求定制最高可支持 -45℃~+115℃); (c). 相对湿度: +20℃时, 不大于 95%; (d). 防护等级: IP55 (可根据用户需求定制)。适用范围: 海拔 0~4000m; (e). 工频耐压: 常开接点: 2000V, 1min, 常闭接点: 1000V, 1min, 对地 2000V, 1min; (f). 常开接点: 2500V, 1000MΩ, 常闭接点: 1000V, 500MΩ, 对地 2500V, 1000MΩ。

Scope of use: (a) Installation position: on the fuel tank cap, on the raised seat, or on the upper side wall of the fuel tank; (b) Environmental requirements: -30 °C to +70 °C (can be customized according to user needs to support up to -45 °C to +70 °C); Work environment requirements: -30 °C ~ +115 °C (customizable according to user needs, can support up to -45 °C ~ +115 °C); (c) Relative humidity: not exceeding 95% at +20 °C; (d) Protection level: IP55 (Customizable according to user requirements). Scope of application: Altitude 0~4000m.; (e) Power frequency withstand voltage: normally open contact: 2000V, 1min, normally closed contact: 1000V, 1min, ground 2000V, 1min; (f) Normally open contact: 2500V, 1000M Ω, normally closed contact: 1000V, 500M Ω, ground 2500V, 1000M Ω.

1.2 信号开关接线图与电气参数 Signal switch wiring diagram and electrical parameters



图 1 二芯常开 (常闭) 接点、四芯双常开 (常闭) 接点压力释放阀接线原理图

Figure 1 Schematic diagram of pressure relief valve wiring for two core normally open (normally closed) contacts and four core double normally open (normally closed) contacts

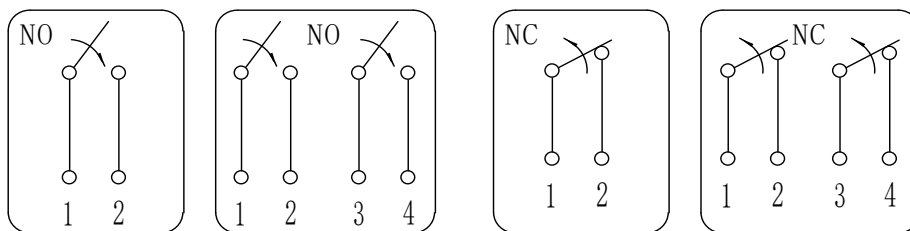

图 2 三芯常开常闭接点、六芯双常开常闭接点压力释放阀接线原理图

Figure 2 Schematic diagram of pressure relief valve wiring for three core normally open and normally closed contacts and six core double normally open and normally closed contacts

表 1 信号开关基本参数(带电气接点的压力释放阀)

Table 1 Basic Parameters of Signal Switch (Pressure Relief Valve with Electrical Contact)

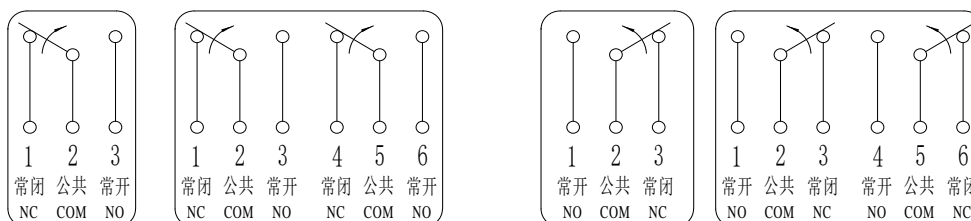
电源种类 Type of power supply	电压(V) Voltage	电流 A Electric current	
		电阻负载 Resistive load	感性负载 Inductive
AC	220V	5	3(cos φ =0.4)
DC		0.3	0.05(T=7ms)

表 2 性能参数

Table 2 Performance Parameters

开启压力 Opening Pressure	开启压力偏差 Open pressure deviation	关闭压力 (不小于) Close the pressure (not less than)	密封压力 (不小于) Sealing pressure (not less than)
15	±5	8	9
25		13.5	15
35		19	21
55		29.5	33
70		37.5	42

二、外形及安装尺寸图 (未表明设计序号的压力释放阀均为九型阀)

Outline and installation dimension diagram (pressure relief valves without specified design numbers are all nine type valves)

2.1、Φ25、Φ50 压力释放阀 (螺纹联接, 带机械报警型) 见图 3-1、表 3-1

Pressure relief valves with diameters of Ø 25 and Ø 50 (threaded connection, with mechanical alarm type) are shown in Figure 3-1 and Table 3-1

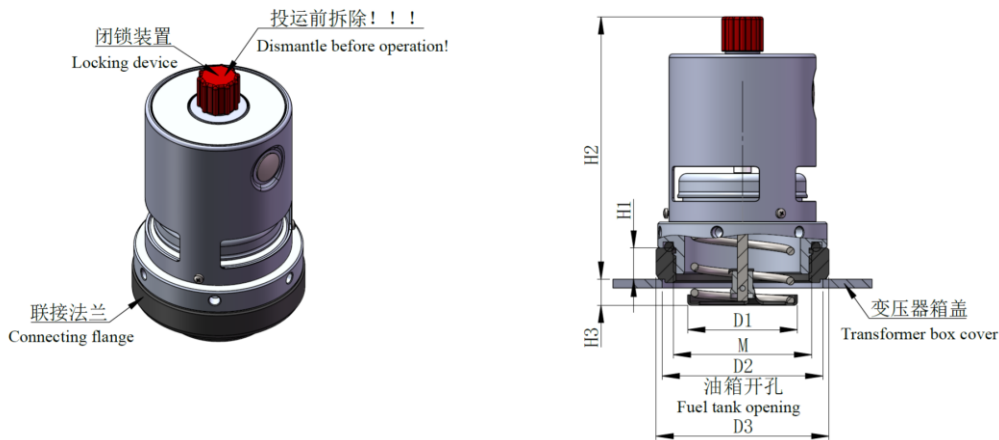

单位 Unit: mm

图 3-1 Figure 3-1

-表 3-1- -Table 3-1-

产品型号 Product model	口径 Caliber	D1	D2	D3	H1	H2	H3	M
YSF9/(6)-XX/25JTHB	Φ25	Φ17.5	Φ55/(Φ40)	Φ60	15	128	11	M38×2
YSF9/(6)-XX/25JTHB	Φ25	Φ17.5	Φ55	Φ62	16	136	11	M48×3
YSF9/(6)-XX/50JTHB	Φ50	Φ64	Φ93/(Φ70)	Φ100	18/(33)	155/(170)	13/(-9)	M80×3

2.2. Φ 25K、 Φ 50K 压力释放阀（螺纹联接，带电气信号，垂直出线，带机械报警）见图 3-2、表 3-2

Pressure relief valves with a diameter of 25K and 50K (threaded connection, electrical signal, vertical output, mechanical alarm) are shown in Figure 3-2 and Table 3-2

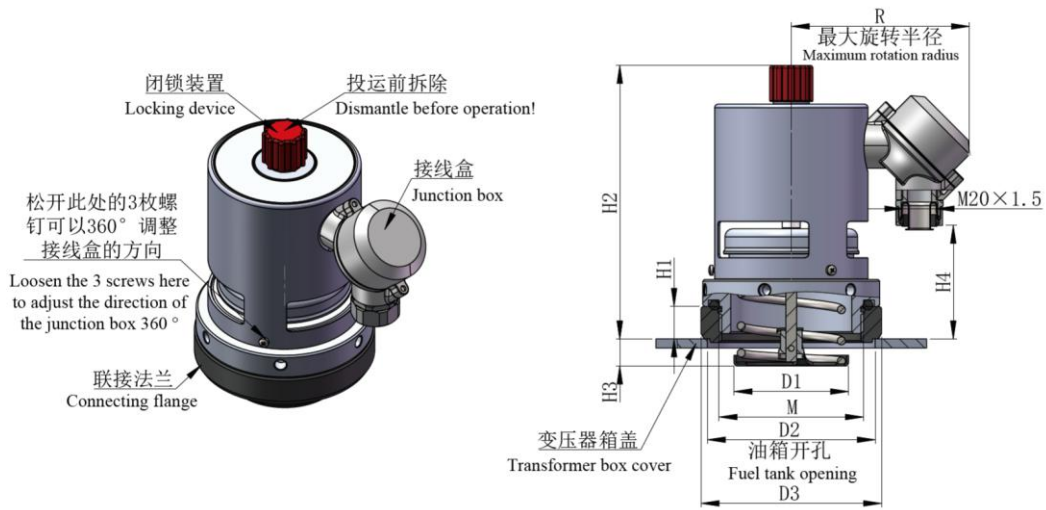

单位 Unit: mm

图 3-2 Figure 3-2

-表 3-2- -Table 3-2-

产品型号 Product model	口径 Caliber	D1	D2	D3	H1	H2	H3	H4	R	M
YSF9(6)-XX/25(S)KJTHB	Φ 25	Φ 17.5	Φ 55/(Φ 40)	Φ 60	15	128	11	30	85	M38 \times 2
YSF9(6)-XX/25(S)KJTHB	Φ 25	Φ 17.5	Φ 55	Φ 62	16	138	11	38	85	M48 \times 3
YSF9(6)-XX/50(S)KJTHB	Φ 50	Φ 64	Φ 93/(Φ 70)	Φ 100	18/(33)	155/(170)	13/(-9)	50(65)	100	M80 \times 3

2.3. Φ 25K、 Φ 50K 压力释放阀（螺纹联接，带电气信号，PG 防水接头，带机械报警）见图 3-3、表 3-3

Pressure relief valves with a diameter of 25K and 50K (threaded connection, electrical signal, PG waterproof joint, mechanical alarm) are shown in Figure 3-3 and Table 3-3

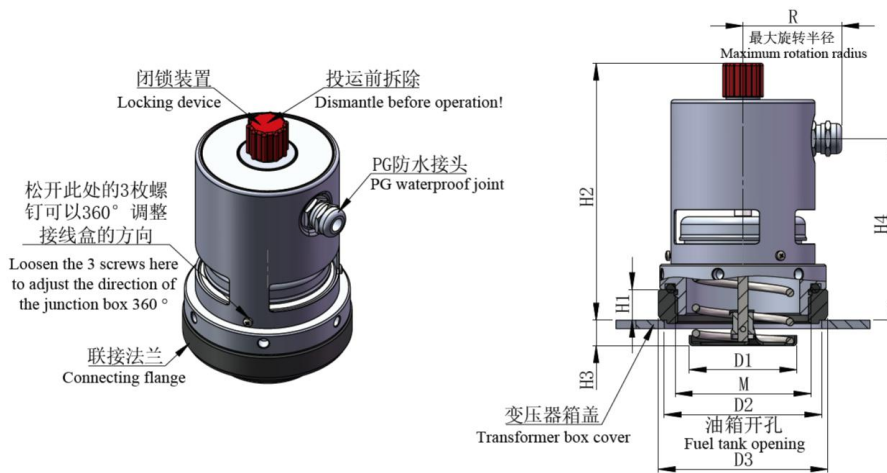

单位 Unit: mm

图 3-3 Figure 3-3

-表 3-3- -Table 3-3-

产品型号 Product model	口径 Caliber	D1	D2	D3	H1	H2	H3	H4	R	M
YSF9(6)-XX/25(S)KJTHB	Φ 25	Φ 17.5	Φ 55/(Φ 40)	Φ 60	15	128	11	86	48	M38 \times 2
YSF9(6)-XX/25(S)KJTHB	Φ 25	Φ 17.5	Φ 55	Φ 62	16	138	11	94	48	M48 \times 3
YSF9(6)-XX/50(S)KJTHB	Φ 50	Φ 64	Φ 93/(Φ 70)	Φ 100	18/(33)	155/(170)	13/(-9)	107(122)	60	M80 \times 3

2.4. Φ25K、Φ50K 压力释放阀（螺纹联接，带电气信号，水平出线，带机械报警）见图 3-4、表 3-4

Pressure relief valves with a diameter of 25K and 50K (threaded connection, electrical signal, horizontal output, mechanical alarm) are shown in Figure 3-4 and Table 3-4

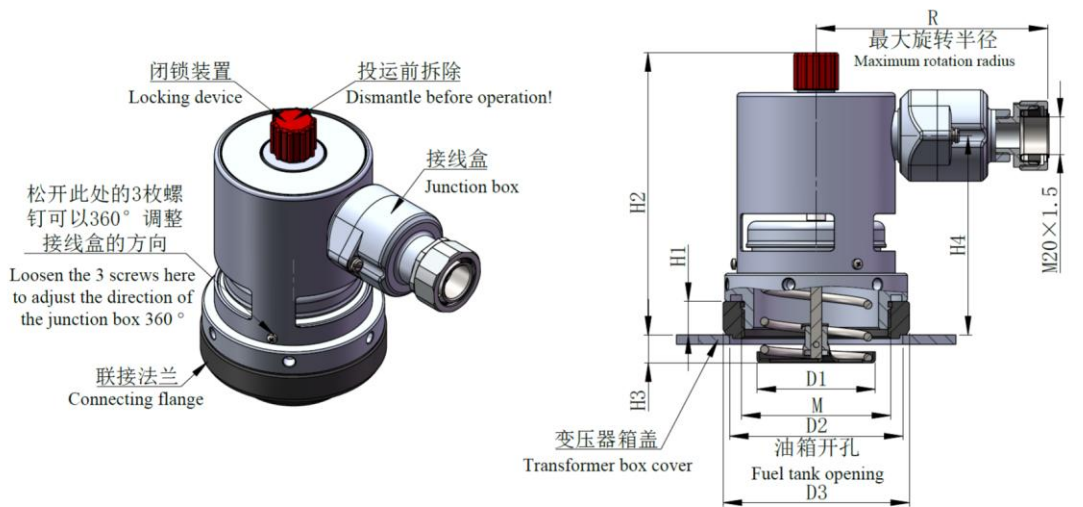

单位 Unit: mm

图 3-4 Figure 3-4

-表 3-4- Table 3-4-

产品型号 Product model	口径 Caliber	D1	D2	D3	H1	H2	H3	H4	R	M
YSF9/(6)-XX/25(S)KJTHB	Φ25	Φ17.5	Φ55/(Φ40)	Φ60	15	128	11	86	117	M38×2
YSF9/(6)-XX/25(S)KJTHB	Φ25	Φ17.5	Φ55	Φ62	16	138	11	94	117	M48×3
YSF9/(6)-XX/50(S)KJTHB	Φ50	Φ64	Φ93/(Φ70)	Φ100	18/(33)	155/(170)	13/(-9)	107(122)	132	M80×3

2.5. 口径为 Φ25D、Φ50D 压力释放阀（螺纹联接，带定向喷油，带机械报警型）见图 3-5、表 3-5

Pressure relief valves (threaded connection, with directional injection, with mechanical alarm type) with dimensions of Ø 25D and Ø 50D are shown in Figure 3-5 and Table 3-5

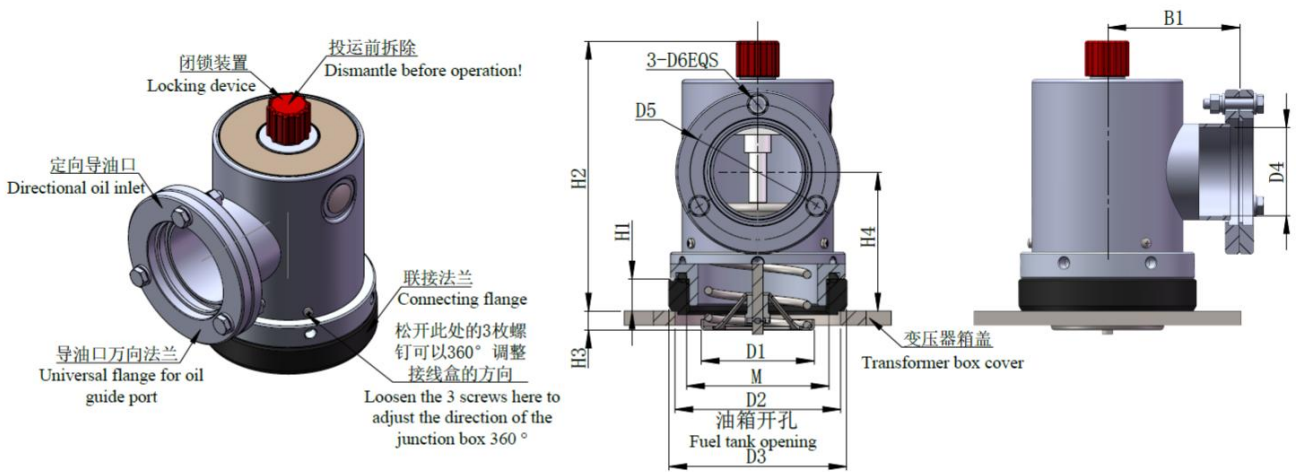

单位 Unit: mm

图 3-5 Figure 3-5

-表 3-5- Table 3-5-

产品型号 Product model	口径 Caliber	D1	D2	D3	D4	D5	D6	B1	H1	H2	H3	H4	M	定向口螺栓数量×规格 Number of directional bolts × specification
YSF9-XX/25DJTHB	Φ25	Φ17.5	Φ55/(Φ40)	Φ60	Φ32	Φ55	Φ8	57	15	128	11	55	M38×2	3×M6-30
YSF9-XX/25DJTHB	Φ25	Φ17.5	Φ55	Φ62	Φ32	Φ55	Φ8	57	16	138	11	63	M48×3	3×M6-30
YSF9-XX/50DJTHB	Φ50	Φ64	Φ93/(Φ70)	Φ100	Φ50	Φ75	Φ8	75	18/(33)	155/(170)	13/(-9)	79/(94)	M80×3	3×M6-35

2.6、口径为Φ25D、Φ50D压力释放阀（螺纹联接，带定向喷油，带电气信号，垂直出线，带机械报警）见图3-6、表3-6

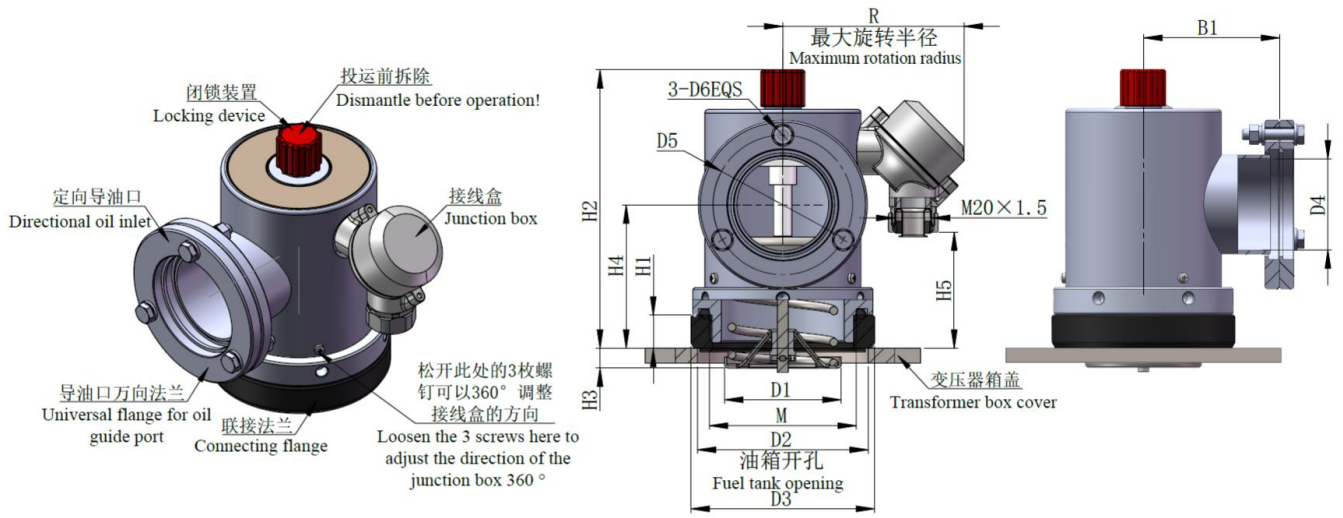
 Pressure relief valves with diameters of $\Phi 25D$ and $\Phi 50D$ (threaded connection, with directional fuel injection, electrical signal, vertical output, and mechanical alarm) are shown in Figure 3-6 and Table 3-6

单位 Unit: mm

图 3-6 Figure 3-6

-表 3-6- -Table 3-6-

产品型号 Product model	口径 Caliber	D1	D2	D3	D4	D5	D6	B1	R	H1	H2	H3	H4	H5	M	定向口螺栓数量×规格 Number of directional bolts × specification
YSF9-XX/ 25D(S)KJTHB	Φ25	Φ17.5	Φ55/ (Φ40)	Φ60	Φ32	Φ55	Φ8	57	85	15	128	11	55	30	M38×2	3×M6-30
YSF9-XX/ 25D(S)KJTHB	Φ25	Φ17.5	Φ55	Φ62	Φ32	Φ55	Φ8	57	85	16	138	11	63	38	M48×3	3×M6-30
YSF9-XX/ 50D(S)KJTHB	Φ50	Φ64	Φ93/ (Φ70)	Φ100	Φ50	Φ75	Φ8	75	100	18/ (33)	155/ (170)	13/ (-9)	79/ (94)	50/ 65	M80×3	3×M6-35

2.7、口径为Φ25D、Φ50D压力释放阀（螺纹联接，带定向喷油，带电气信号，PG防水接头，带机械报警）见图3-7、表3-7

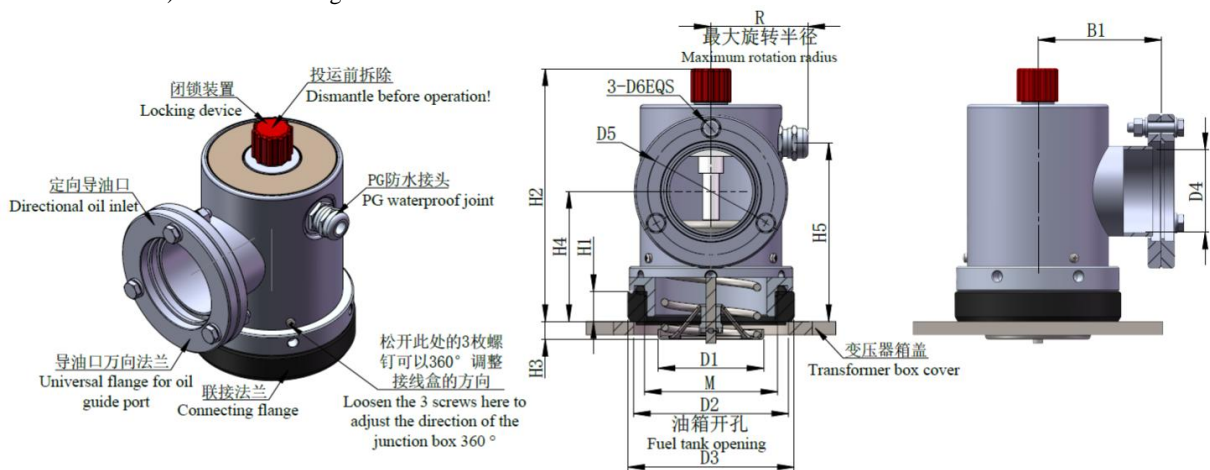
 Pressure relief valves with diameters of $\Phi 25D$ and $\Phi 50D$ (threaded connection, directional fuel injection, electrical signal, PG waterproof joint, mechanical alarm) are shown in Figure 3-7 and Table 3-7

单位 Unit: mm

图 3-7 Figure 3-7

-表 3-7- -Table 3-7-

产品型号 Product model	口径 Caliber	D1	D2	D3	D4	D5	D6	B1	R	H1	H2	H3	H4	H5	M	定向口螺栓数量×规格 Number of directional bolts × specification
YSF9-XX/ 25D(S)KJTHB	Φ25	Φ17.5	Φ55/ (Φ40)	Φ60	Φ32	Φ55	Φ8	57	48	15	128	11	55	86	M38×2	3×M6-30
YSF9-XX/ 25D(S)KJTHB	Φ25	Φ17.5	Φ55	Φ62	Φ32	Φ55	Φ8	57	48	16	138	11	63	94	M48×3	3×M6-30
YSF9-XX/ 50D(S)KJTHB	Φ50	Φ64	Φ93/ (Φ70)	Φ100	Φ50	Φ75	Φ8	75	60	18/ (33)	155/ (170)	13/ (-9)	79/ (94)	107/ (122)	M80×3	3×M6-35

2.8、口径为Φ25D、Φ50D压力释放阀（螺纹联接，带定向喷油，带电气信号，水平出线，带机械报警）见图3-8、表3-8

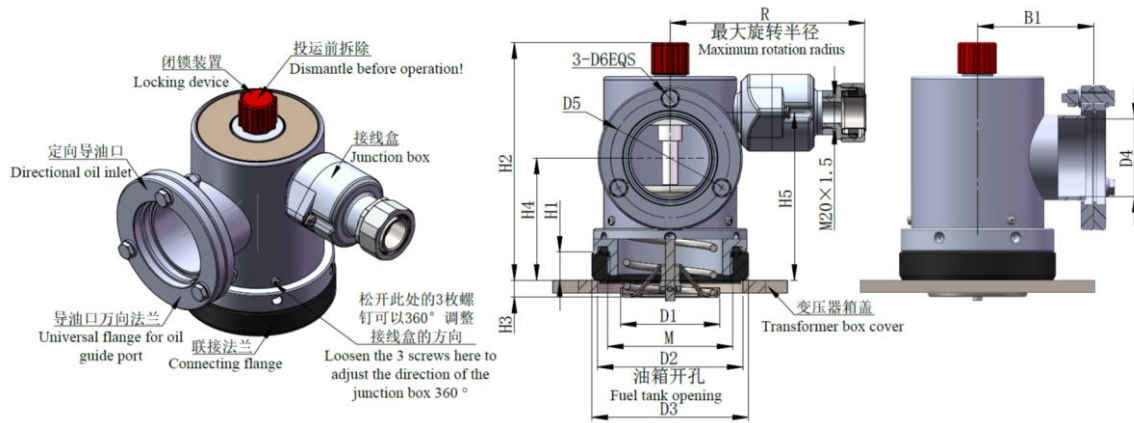
 Pressure relief valves with diameters of $\Phi 25D$ and $\Phi 50D$ (threaded connection, directional injection, electrical signal, horizontal output, mechanical alarm) are shown in Figure 3-8 and Table 3-8

单位 Unit: mm

图 3-8 Figure 3-8

-表 3-8- -Table 3-8-

产品型号 Product model	口径 Caliber	D1	D2	D3	D4	D5	D6	B1	R	H1	H2	H3	H4	H5	M	定向口螺栓数量×规格 Number of directional bolts × specification
YSF9-XX/ 25D(S)KJTHB	Φ25	Φ17.5	Φ55/ (Φ40)	Φ60	Φ32	Φ55	Φ8	57	117	15	128	11	55	86	M38×2	3×M6-30
YSF9-XX/ 25D(S)KJTHB	Φ25	Φ17.5	Φ55	Φ62	Φ32	Φ55	Φ8	57	117	16	138	11	63	94	M48×3	3×M6-30
YSF9-XX/ 50D(S)KJTHB	Φ50	Φ64	Φ93/ (Φ70)	Φ100	Φ50	Φ75	Φ8	75	132	18/ (33)	155/ (170)	13/ (-9)	79/ (94)	107/ (122)	M80×3	3×M6-35

2.9、Φ25、Φ50压力释放阀（螺栓联接，带机械报警型）见图3-9、表3-9

Pressure relief valves (bolted connection, with mechanical alarm type) with a diameter of 25 and 50 are shown in Figure 3-9 and Table 3-9

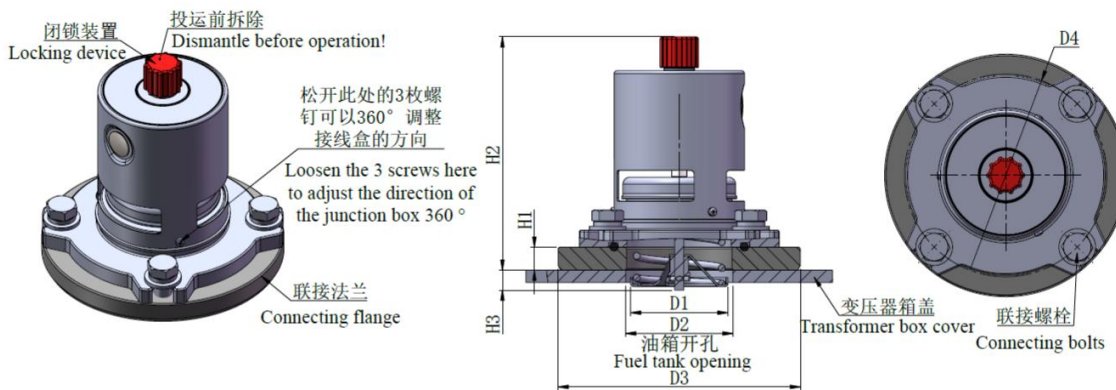

单位 Unit: mm

图 3-9 Figure 3-9

-表 3-9- -Table 3-9-

产品型号 Product model	口径 Caliber	D1	D2	D3	D4	H1	H2	H3	联接螺栓 Connecting bolts
YSF9(4)-XX/25(S)KJTHB	Φ25	Φ17.5	Φ60	Φ108	Φ90	14	140	5	3-M10×20
YSF9(4)-XX/50(S)KJTHB	Φ50	Φ64	Φ70	Φ158	Φ130	15	162	12	4-M12×25

2.10、Φ25K、Φ50K 压力释放阀（螺栓联接，带电气信号，垂直出线，带机械报警）见图 3-10、表 3-10

Pressure relief valves with bolt connection, electrical signal, vertical outgoing line, and mechanical alarm for sizes of 25K and 50K are shown in Figure 3-10 and Table 3-10

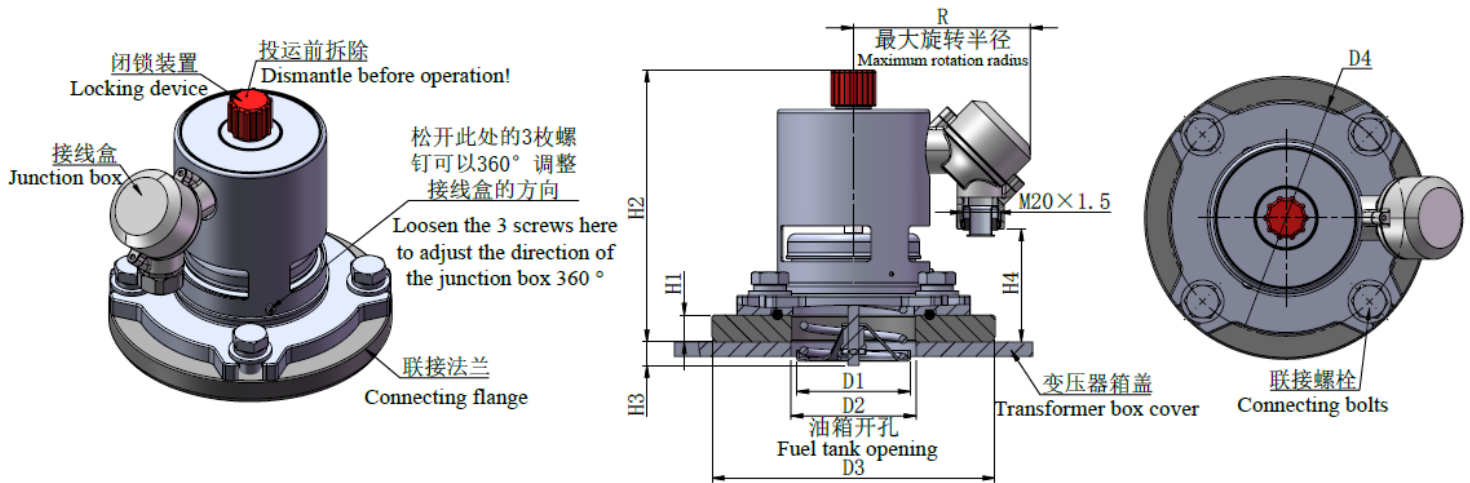

单位 Unit: mm

图 3-10 Figure 3-10

-表 3-10- -Table 3-10-

产品型号 Product model	口径 Caliber	D1	D2	D3	D4	H1	H2	H3	H4	R	联接螺栓 Connecting bolts
YSF9(4)-XX/25(S)KJTHB	Φ25	Φ17.5	Φ60	Φ108	Φ90	14	140	5	95	48	3-M10×20
YSF9(4)-XX/50(S)KJTHB	Φ50	Φ64	Φ70	Φ158	Φ130	15	162	12	115	60	4-M12×25

2.11、Φ25K、Φ50K 压力释放阀（螺栓联接，带电气信号，PG 防水接头，带机械报警）见图 3-11、表 3-11

Pressure relief valves with bolt connection, electrical signal, PG waterproof joint, and mechanical alarm, with a diameter of 25K and 50K, as shown in Figure 3-11 and Table 3-11

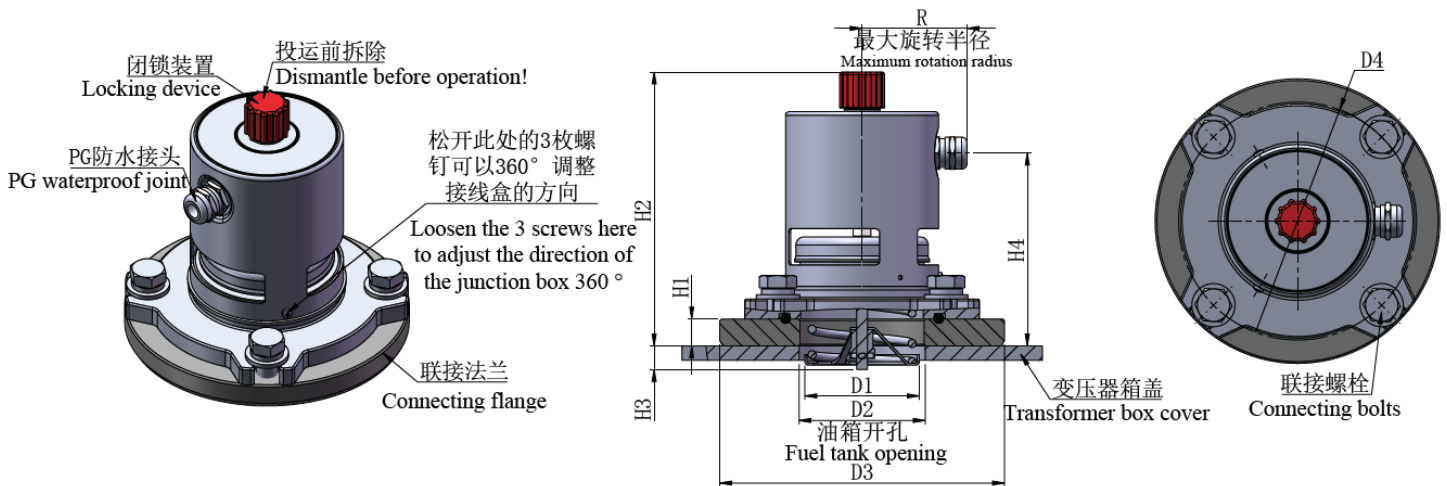

单位 Unit: mm

图 3-11 Figure 3-11

-表 3-11- -Table 3-11-

产品型号 Product model	口径 Caliber	D1	D2	D3	D4	H1	H2	H3	H4	R	联接螺栓 Connecting bolts
YSF9(4)-XX/25(S)KJTHB	Φ25	Φ17.5	Φ60	Φ108	Φ90	14	140	5	30	85	3-M10×20
YSF9(4)-XX/50(S)KJTHB	Φ50	Φ64	Φ70	Φ158	Φ130	15	162	12	58	100	4-M12×25

2.12、Φ25K、Φ50K 压力释放阀（螺栓联接，带电气信号，水平出线，带机械报警）见图 3-12、表 3-12

Pressure relief valves with bolt connection, electrical signal, horizontal outlet, and mechanical alarm for sizes of 25K and 50K are shown in Figure 3-12 and Table 3-12

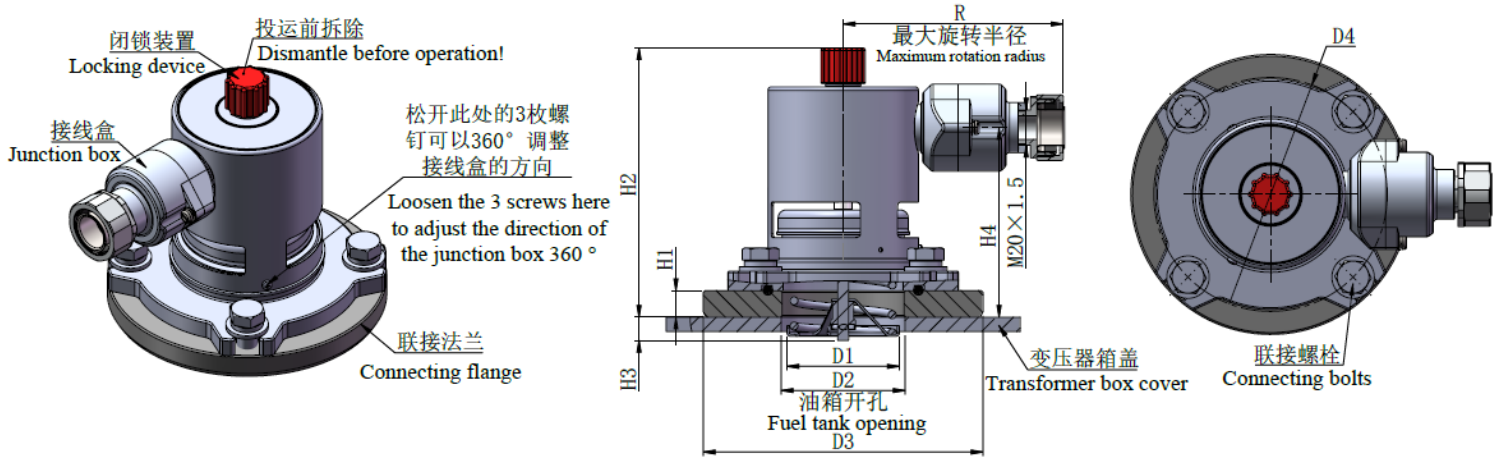

单位 Unit: mm

图 3-12 Figure 3-12

-表 3-12- Table 3-12-

产品型号 Product model	口径 Caliber	D1	D2	D3	D4	H1	H2	H3	H4	R	联接螺栓 Connecting bolts
YSF9(4)-XX/25(S)KJTHB	Φ25	Φ17.5	Φ60	Φ108	Φ90	14	140	5	95	117	3-M10×20
YSF9(4)-XX/50(S)KJTHB	Φ50	Φ64	Φ70	Φ158	Φ130	15	162	12	115	132	4-M12×25

2.13、Φ25DK、Φ50DK 压力释放阀（螺栓联接，带定向喷油,带机械报警型）见图 3-13、表 3-13;

Pressure relief valves (bolted connection, with directional injection, and mechanical alarm type) with a diameter of 25DK and 50DK are shown in Figure 3-13 and Table 3-13

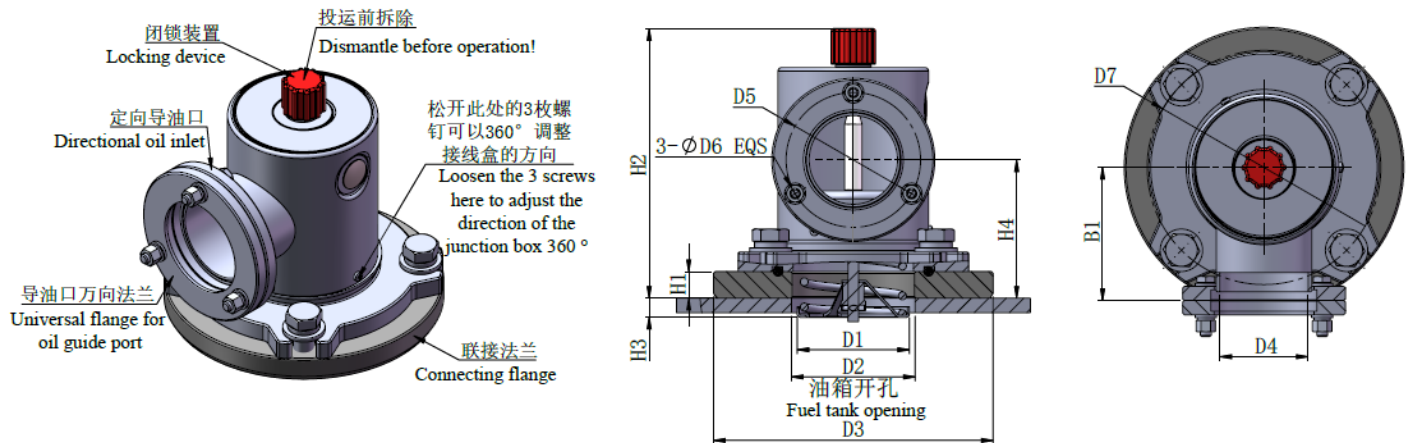

单位 Unit: mm

图 3-13 Figure 3-13

-表 3-13- Table 3-13-

产品型号 Product model	口径 Caliber	D1	D2	D3	D4	D5	D6	D7	H1	H2	H3	H4	B1	联接螺栓 Connecting bolts	定向口螺栓数量×规格 Number of directional bolts × specification
YSF9(8)-XX/25D(S)KJTHB	Φ25	Φ17.5	Φ60	Φ108	Φ32	Φ55	Φ8	Φ90	14	140	5	68	57	3-M10×20	3×M6-30
YSF9(8)-XX/50D(S)KJTHB	Φ50	Φ64	Φ70	Φ158	Φ50	Φ75	Φ8	Φ130	15	162	12	85	75	4-M12×25	3×M6-35

2.14、Φ25DK、Φ50DK 压力释放阀（螺栓联接，带定向喷油，带电气信号，垂直出线，带机械报警）见图 3-14、表 3-14；

Pressure relief valves with bolt connection, directional fuel injection, electrical signal, vertical output, and mechanical alarm for the models of Ø 25DK and Ø 50DK are shown in Figure 3-14 and Table 3-14;

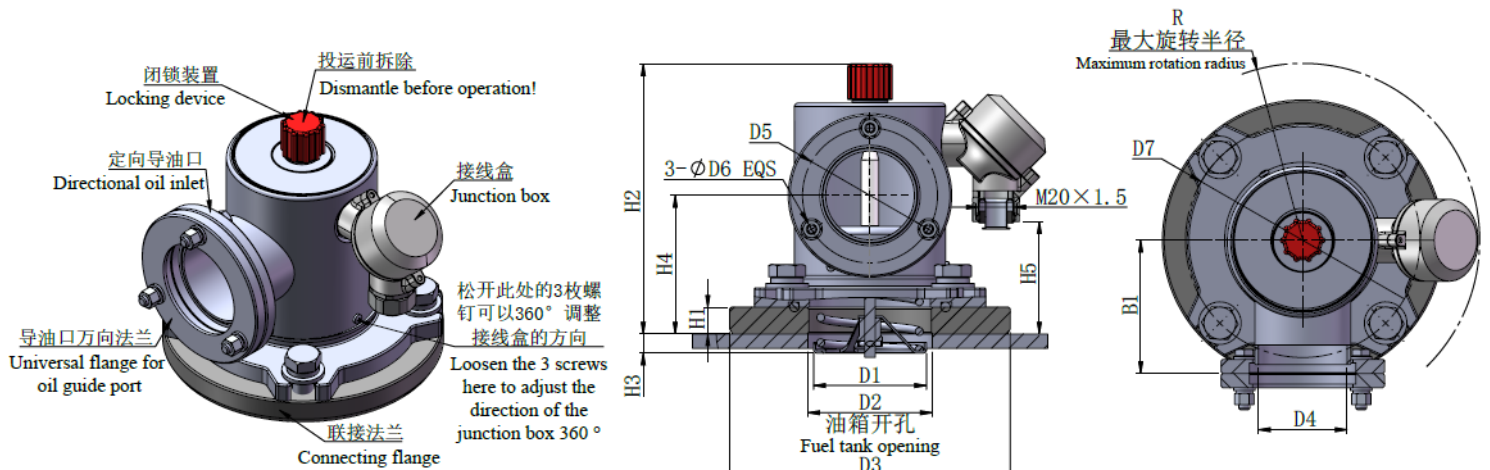

单位 Unit: mm

图 3-14 Figure 3-14

-表 3-14- -Table 3-14-

产品型号 Product model	口径 Caliber	D1	D2	D3	D4	D5	D6	D7	H1	H2	H3	H4	H5	B1	R	联接螺栓 Connecting bolts	定向口螺栓数量×规格 Number of directional bolts × specification
YSF9(8)-XX/25 D(S)KJTHB	Φ25	Φ17.5	Φ60	Φ108	Φ32	Φ55	Φ8	Φ90	14	140	5	68	30	57	85	3-M10×20	3×M6-30
YSF9(8)-XX/50 D(S)KJTHB	Φ50	Φ64	Φ70	Φ158	Φ50	Φ75	Φ8	Φ130	15	162	12	85	58	75	100	4-M12×25	3×M6-35

2.15、Φ25DK、Φ50DK 压力释放阀（螺栓联接，带定向喷油，带电气信号，PG 防水接头，带机械报警）见图 3-15、表 3-15；

Pressure relief valves with bolt connection, directional fuel injection, electrical signal, PG waterproof joint, and mechanical alarm for sizes of Ø 25DK and Ø 50DK are shown in Figure 3-15 and Table 3-15

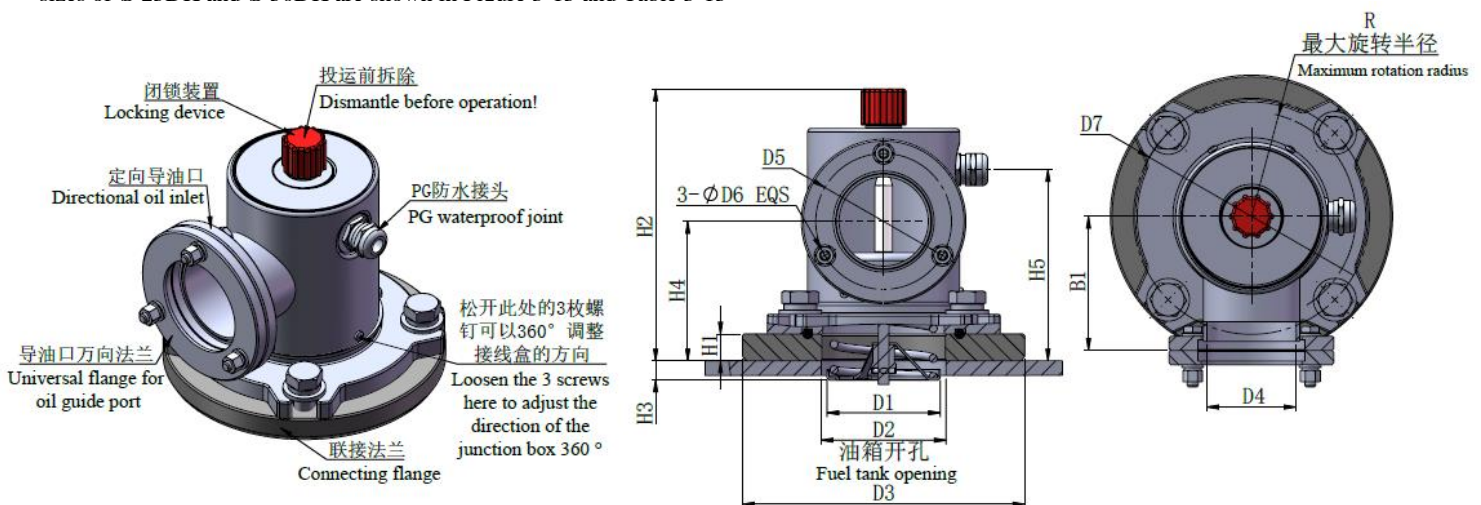

单位 Unit: mm

图 3-15 Figure 3-15

-表 3-15- -Table 3-15-

产品型号 Product model	口径 Caliber	D1	D2	D3	D4	D5	D6	D7	H1	H2	H3	H4	H5	B1	R	联接螺栓 Connecting bolts	定向口螺栓数量×规格 Number of directional bolts × specification
YSF9(8)-XX/25 D(S)KJTHB	Φ25	Φ17.5	Φ60	Φ108	Φ32	Φ55	Φ8	Φ90	14	140	5	68	95	57	48	3-M10×20	3×M6-30
YSF9(8)-XX/50 D(S)KJTHB	Φ50	Φ64	Φ70	Φ158	Φ50	Φ75	Φ8	Φ130	15	162	12	85	115	75	60	4-M12×25	3×M6-35

2.16、Φ25DK、Φ50DK 压力释放阀（螺栓联接，带定向喷油，带电气信号，水平出线，带机械报警）见图 3-16、表 3-16；

Pressure relief valves with bolt connection, directional fuel injection, electrical signal, horizontal outlet, and mechanical alarm for the models of $\Phi 25DK$ and $\Phi 50DK$ are shown in Figure 3-16 and Table 3-16

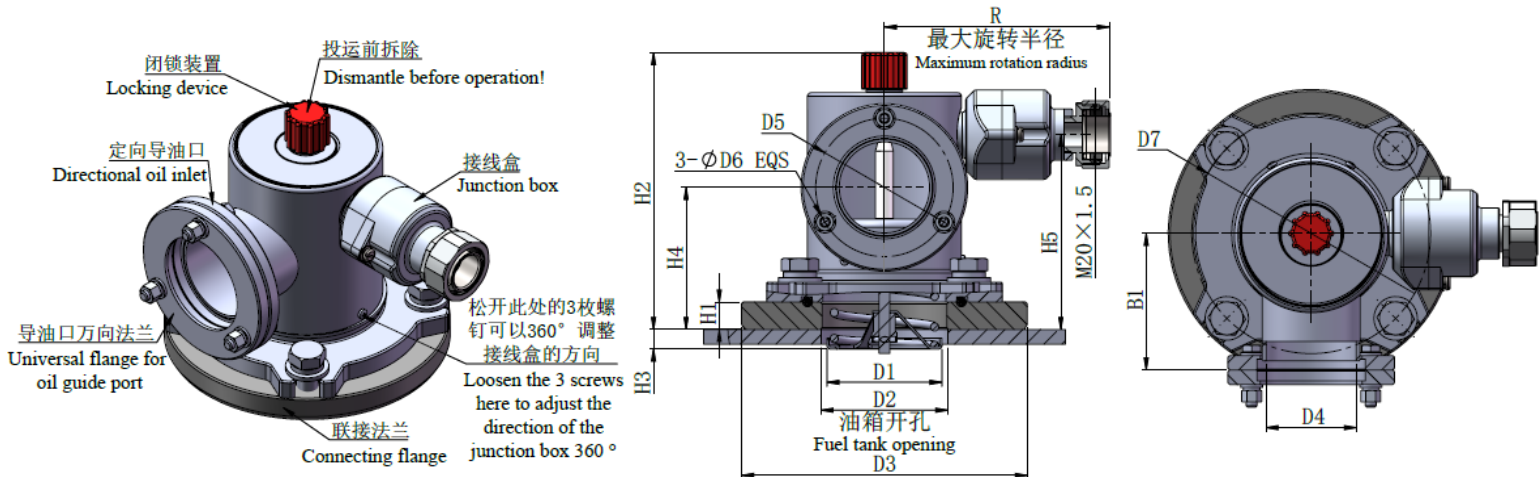

单位 Unit: mm

图 3-16 Figure 3-16

-表 3-16- Table 3-16-

产品型号 Product model	口径 Caliber	D1	D2	D3	D4	D5	D6	D7	H1	H2	H3	H4	H5	B1	R	联接螺栓 Connecting bolts	定向口螺栓数量×规格 Number of directional bolts × specification
YSF9(8)-XX/25 D(S)KJTHB	Φ25	Φ17.5	Φ60	Φ108	Φ32	Φ55	Φ8	Φ90	14	140	5	68	95	57	117	3-M10×20	3×M6-30
YSF9(8)-XX/50 D(S)KJTHB	Φ50	Φ64	Φ70	Φ158	Φ50	Φ75	Φ8	Φ130	15	162	12	85	115	75	132	4-M12×25	3×M6-35

本产品提供多种颜色选择，具体描述如下：

The product provides a variety of color options, specifically described as follows:

色卡编号 Color card No	颜色 Color	可选性 Optionality of choice
RAL7038	玛瑙灰 Agate grey	默认 (Default)
RAL7042	交通灰 A Traffic grey A	可选 (Optional)
RAL7035	浅灰色 Light grey	可选 (Optional)

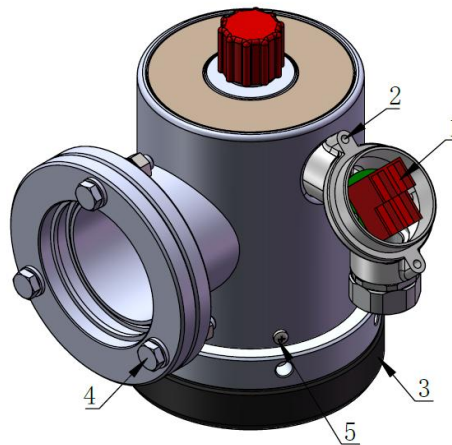

扭矩参考表

Torque Reference Table

序号 Number	装配位置 Assembly position	螺纹规格 Thread specification	推荐扭矩 Recommended torque	装配工具规格 Assembly tool specifications	备注 Notes		
1	接线端子 Connecting terminal	M3	0.5~1Nm		建议手动安装 Suggest manual installation		
2	接线盒盖 Terminal box cover	M4	1.5~2Nm		建议手动安装 Suggest manual installation		
3	法兰安装孔 Flange installation hole	Φ25 螺纹连接 threaded connection	M38×2	60±3Nm			
		Φ25 螺纹连接 threaded connection	M48×3	70±3Nm			
		Φ50 螺纹连接 threaded connection	M80×3	90±3Nm			
		Φ25 螺栓连接 bolted connection	M10 螺栓 bolt	18~22Nm		17mm	
		Φ50 螺栓连接 bolted connection	M12 螺栓 bolt	35~40Nm		19mm	
4	定向导油口 Directional oil inlet	M6	6~8Nm		10mm		
5	电气罩 Electrical hood	M3	0.5~1Nm		建议手动安装 Suggest manual installation		

三、防雨罩装配示意图(选装) Rainproof cover assembly diagram (optional)

安装方式 1 Installation method 1

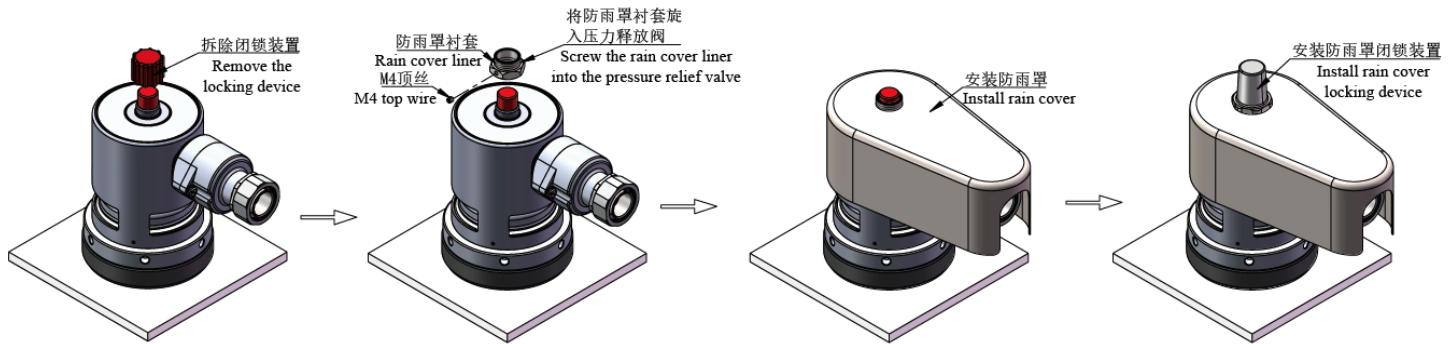

安装方式 2 Installation method 2

