

BWY 系列变压器油面温控器

BWY Top-oil temperature indicators for transformers

一. 产品简介(Product introduction)

BWY 系列温度指示控制器是采用复合测温的原理而设计的。适用于其它设备的温度检测和控制。该仪表具有良好的防护性能，能在户外条件下正常工作,仪表内装有四组或六组可调控制开关，可分别用于变压器冷却系统启动、讯号报警。同时能将温度信号远传至控制中心，同步显示，控制变压器油温。

BWY 系列温度指示控制器，主要由弹性元件、传感导管、感温部件及数显仪组成。弹性元件、传感导管和感温部件构成的密封系统内充满感温介质，当被测温度变化时，感温部件内的感温介质的体积随之变化，这个体积增量通过传感导管传递到仪表内弹性元件，使之产生一个相对应的位移，这个位移经机构放大后便可指示被测温度，并驱动微动开关输出开、关控制信号以驱动冷却系统,达到控制变压器温升的目的。通过嵌装在温包上端引长管内的 Pt100 铂热电阻 信号，供控制室的二次仪表使用。

The series of BWY temperature indicating controller is designed based on the principle of composite temperature rise. It is suitable for temperature detection and control of other equipment. The instrument has good protective performance and can work normally under outdoor conditions. It is equipped with four or six adjustable control switches, which can be used separately for the start-up of transformer cooling systems and signal alarms. At the same time, it can transmit temperature signals to the control center for Synchronous display and control of the transformer oil temperature.

The series of BWY temperature indicating controller mainly consists of elastic elements, sensing conduits, temperature sensing components, and a digital display instrument. The sealed system formed by the elastic elements, sensing conduits, and temperature sensing components is filled with a temperature-sensitive medium. When the measured temperature changes, the volume of the temperature-sensitive medium inside the temperature sensing component also changes accordingly. This volume increase is transmitted through the Sensing conduit to the elastic element inside the instrument, causing a corresponding displacement. After being amplified by the mechanism, this displacement indicates the measured temperature and drives micro switches to output on/off control signals to drive the cooling system, achieving the purpose of controlling the temperature rise of the transformer. The signal from the Pt100 platinum thermal resistance embedded in the elongated tube on the upper end of the temperature package is used by the secondary instrument in the control room.

二. 型号、规格、结构、特点(Model, specification, structure, characteristics)

2.1、型号及说明(Model and description)

BWY - 80 4/6 AJ (TH)

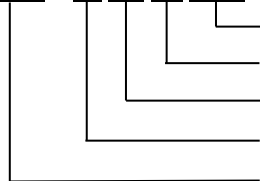

三防要求加标 TH Three defense requirements are marked with TH

A:输出 Pt100 铂电阻值, J: 输出 4-20mA A: Output Pt100 platinum thermistor value, J: Output 4-20mA

开关数量 Number of switches

线性刻度 Linear scale

变压器油面温控器 Oil temperature indicators for transformers

2.2、主要技术参数及性能(Main technical parameters and performance):

2.2.1. 输出信号:Pt100 铂电阻值、4-20mA。

Output signal: Pt100 platinum resistance value, 4-20mA.

2.2.2. 工作条件:环境温度(-40~+55) °C、相对湿度≤95%。

Working conditions: Environmental temperature (-40-+55) °C , relative humidity ≤95%.

2.2.3. 测量范围:常规(0~150)°C。其他范围可以定制。

Measurement range: Conventional (0-150) °C.Other ranges can be customized.

2.2.4. 准确度:1.5 级。

Accuracy: Level 1.5.

2.2.5. 开关性能:四、六组可调开关, 各组开关均能在全量程内任意设定。

Switching performance: Four or six sets of adjustable switches, each set of switches can be set arbitrarily within the full range.

2.2.6. 开关动作误差: $\pm 4^{\circ}\text{C}$ 。

Switching action error: $\pm 4^{\circ}\text{C}$

2.2.7. 开关切换差: $(6\pm 2)^{\circ}\text{C}$ 。

Switching action error: $(6\pm 2)^{\circ}\text{C}$

2.2.8. 开关额定功率:AC220V 5A。

Rated power of switch: AC220V 5A.

2.2.9. 温包尺寸:($\Phi 14 \times 150$)mm、安装螺纹为(M27×2)mm。

Temperature bulb size: ($\Phi 14 \times 150$) mm, with an installation thread of (M27 × 2)mm.

2.2.10.毛细管长度常规 6m.其他长度可以定制。

The regular length of the capillary tube is 6m. Other lengths can be customized.

2.2.11. 防护等级: IP55。

Protection level: IP55

2.3、外形及安装尺寸图(Shape and installation dimension drawing)

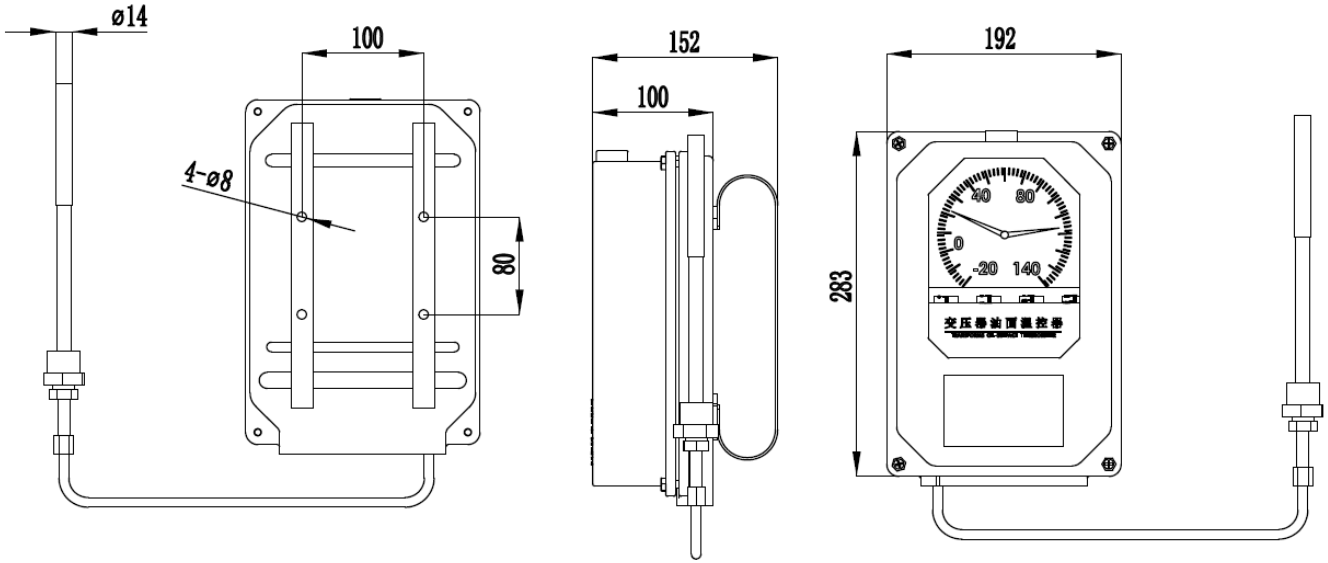

2.4、电气接线原理图及功能详解(Electrical wiring schematic diagram and detailed function explanation)

